

Solar Modules with 72 Cells

Mono-Crystalline

SRM160D~185D

Module Type	Number of Cell	Cell Dimension(mm)	Max System Voltage(V)	Pm(W)	Vm(V)	Im(A)	Voc(V)	Isc(A)
SRM-160D	72	125×125	DC700	160	34.5	4.64	43.2	5.07
SRM-165D	72	125×125	DC700	165	35.4	4.66	43.6	5.08
SRM-170D	72	125×125	DC700	170	35.6	4.78	44.2	5.15
SRM-175D	72	125×125	DC700	175	35.8	4.89	44.2	5.25
SRM-180D	72	125×125	DC700	180	36.2	4.97	44.2	5.36
SRM-185D	72	125×125	DC700	185	36.3	5.10	44.2	5.51

Poly-Crystalline

SRM160P~175P

Module Type	Number of Cell	Cell Dimension(mm)	Max System Voltage(V)	Pm(W)	Vm(V)	Im(A)	Voc(V)	Isc(A)
SRM-160P	72	125 × 125	DC700	160	34.5	4.64	43.2	4.98
SRM-165P	72	125 × 125	DC700	165	34.8	4.74	43.3	5.09
SRM-170P	72	125 × 125	DC700	170	35.2	4.83	43.5	5.21
SRM-175P	72	125 × 125	DC700	175	35.5	4.93	43.6	5.29

Picture



SRM160D~185D



SRM160P~175P

Structure

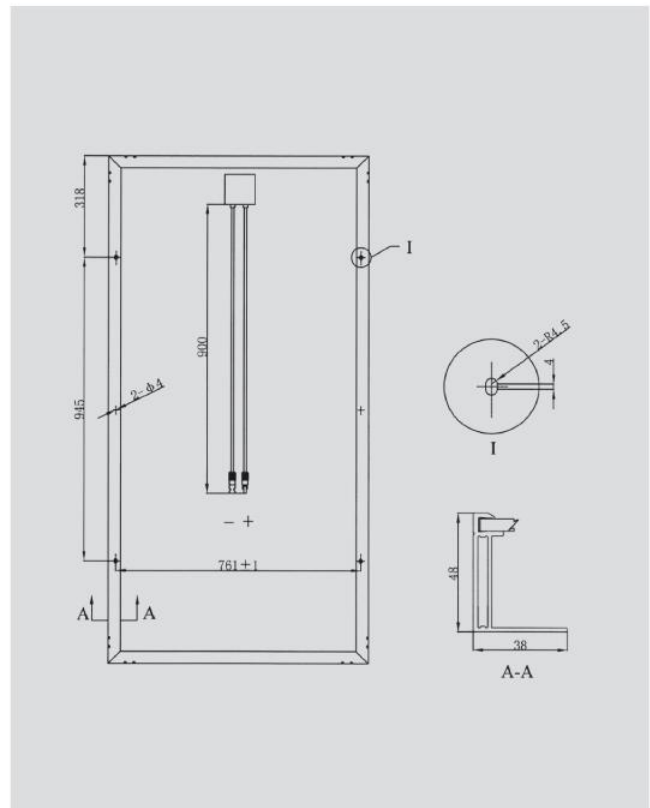

Physical Characters

Module Net Weight	16.5(kg)
Module Size	1581×809×48(mm)
Carton Size	1615×845×110(mm)
Packing Configuration	2pcs/carton 18cartons/pallet
Loading Capacity	280pcs/7pallets/20'container 560pcs/14pallets/40'container

TO CREATE A SUSTAINABLE FUTURE
创造可持续发展的未来

常州兆阳光能科技有限公司
SUNRISE SOLARTECH CO., LTD.

地址: 常州市钟楼开发区科技工业园星港路65-22号

电话: 0086-519-83906509(总机)

0086-519-83906507(贸易部)

传真: 0086-519-83906508

网址: www.srsolartech.com

Add: No. 65-22 Xinggang Road, Zhongliou Development

Zone, Changzhou 213023 Jiangsu, P. R. China

Tel: 0086-519-83906509

0086-519-83906507

Fax: 0086-519-83906508

Http: //www.srsolartech.com