

stored energy solutions for a demanding world



Model : 6-FM-7

GP SERIES

General Series

General Series Valve Regulated Lead Acid batteries are designed with AGM (Absorbent Glass Mat) technology, high performance plates and electrolyte to gain extra power output for common power backup system applications widely used in the field of UPS, Emergency Lighting System.

Application

- Alarm System
- Cable Television
- Communication Equipment
- Control Equipment
- Security System
- Medical Equipment
- UPS
- Power tools
- Emergency Power System
- Toys

General Features

- Sealed and maintenance free operation.
- Non-Spillable construction design.
- ABS containers and covers(UL94HB, UL94V-0) optional.
- Safety valve installation for explosion proof.
- High quality and high reliability.
- Exceptional deep discharge recovery performance.
- Low self discharge characteristic.
- Flexibility design for multiple install positions.

Construction

- ComponentRaw material
- PositiveLead dioxide
- NegativeLead
- ContainerABS
- CoverABS
- SealantEpoxy Resin
- Safety valveEPDR
- TerminalCopper
- SeparatorFiber glass
- ElectrolyteSulfuric acid

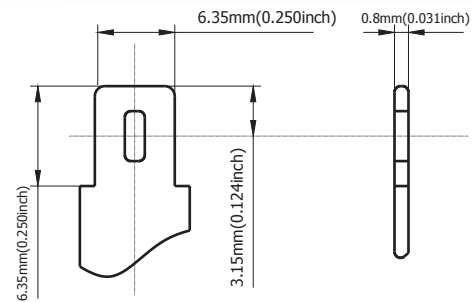

Terminal Dimensions

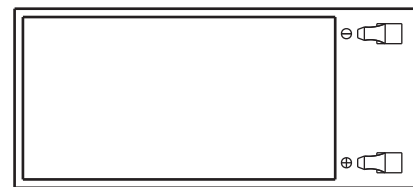
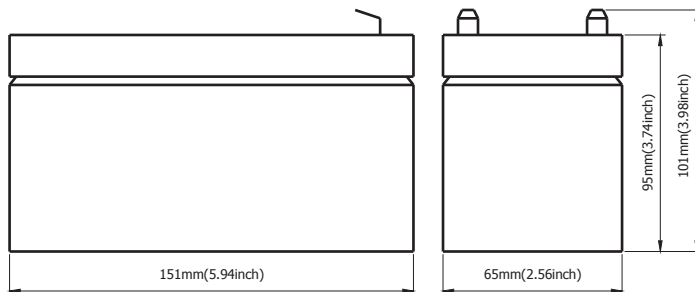

Battery Model	6-FM-7			
Designed Floating Life	5 Years			
Capacity(25°C)	20HR(0.35A,1.80V)	10HR(0.67A,1.80V)	5HR(1.18A,1.75V)	1HR(5.27A,1.60V)
	7.0AH	6.7AH	5.9AH	5.27AH
Dimensions	Length	Width	Height	Total Height
	151mm(5.94inch)	65mm(2.56inch)	95mm(3.74inch)	101mm(3.98inch)
Approx. Weight	2.1Kg (4.63 lbs)			
Internal Resistance	Full charged at 25°C: 0.02 Ohm			
Self Discharge	3% of capacity declined per month at (25°C)			
Capacity Affected by Temp.(20HR)	40°C	25°C	0°C	-15°C
	108%	100%	85%	65%
Charge Voltage(25°C)	Cycle use		Float use	
	14.4-14.8V(-30mV/ °C), max. Current: 2.1A		13.6-13.8V(-20mV/ °C)	

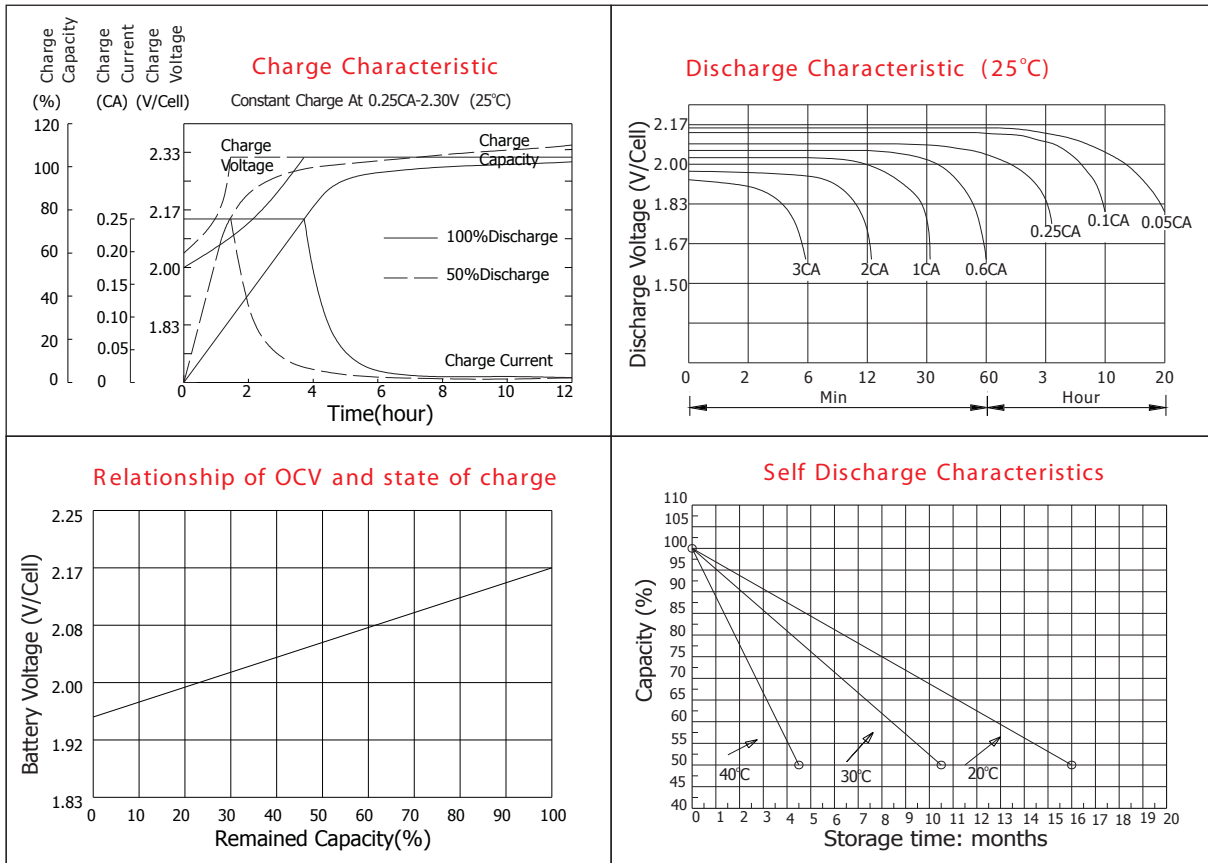

Constant current discharge ratings-amperes at 25°C

F.V/Time	5MIN	10MIN	15MIN	30MIN	1HR	3HR	5HR	10HR	20HR
1.60V	31.2	19.6	14.9	9.24	5.27	2.27	1.33	0.70	0.39
1.67V	29.3	18.6	14.3	8.83	5.20	2.18	1.31	0.70	0.38
1.70V	26.8	17.7	14.0	8.03	5.05	2.04	1.28	0.69	0.37
1.75V	26.3	16.6	13.5	7.63	4.94	1.97	1.25	0.68	0.36
1.80V	23.5	14.4	12.3	7.07	4.76	1.89	1.18	0.67	0.35
1.85V	20.7	12.3	11.1	6.50	4.43	1.82	1.10	0.66	0.34

Constant power discharge ratings-watts at 25°C

F.V/Time	5MIN	10MIN	15MIN	30MIN	1HR	3HR	5HR	10HR	20HR
1.60V	56.3	36.3	28.0	17.1	9.79	4.14	2.32	1.44	0.81
1.67V	54.3	35.4	27.6	16.8	9.73	4.01	2.31	1.43	0.78
1.70V	51.1	35.1	27.4	15.7	9.55	3.83	2.28	1.43	0.77
1.75V	51.4	35.0	27.1	15.2	9.38	3.74	2.26	1.41	0.75
1.80V	47.1	29.5	25.2	14.5	8.84	3.63	2.19	1.39	0.73
1.85V	42.7	25.1	22.8	13.6	8.31	3.52	2.12	1.37	0.70

NARADA POWERSOURCE CO.,LTD.
No.459 Wensan Road, Hangzhou, Zhejiang, P.R.China
Tel:+86-571-28827013 Fax:+86-571-23657189
Website:www.naradabattery.com E-mail:intl@narada.biz

NARADA ASIA PACIFIC PTE.LTD.
65 Ubi Crescent #07-05 HOLA centre, Singapore
Tel: +65-6848 1191 Fax: +65-6749 3498
E-mail:sales@narada.com.sg

NARADA EUROPE (UK) LIMITED
Spectrum House, Dunstable Road, Redbourn,
St. Albans, Herts AL3 7PR
Tel: +44 (0)845 371 7095 Fax:+44 (0)845 612 2031
E-mail:sales@naradaeurope.com

